

- NOTES:
- 1- THE TRAYER CAT.# 901A LIQUID LEVEL GAUGE IS A COMPLETELY STATIC DEVICE THAT ACTUALLY READS "LOW OIL" IF THE OIL DROPS BELOW PROPER LEVEL IT IS AVAILABLE TO ALL SWITCH AND TRANSFORMER MANUFACTURERS IN ORDER TO PROMOTE INDUSTRY STANDARDIZATION.
  - 2- DECAL READS:  
"BREAKER TRIPPED WHEN YELLOW INDICATOR PROJECTS IN TO THE SIGHT GLASS. TO RESET BREAKER, OPEN AND CLOSE OPERATING HANDLE"
  - 3- DECAL READS:  
"WARNING - POTENTIAL TRANSFORMER FUSE ENERGIZED FROM SWITCHGEAR BUS. TO CHANGE FUSE FIRST DE-ENERGIZE BUS."
  - 4- MATERIAL:  
OIL TANK : 7 GA.  
TANK TOP & BASE : 11GA.  
LIFT UP HOODS : 14 GA.
  - 5- DECAL READS:  
LIQUID LEVEL INDICATOR READS "LOW OIL" WHEN OIL IS LOW.
  - 6- DECAL READS:  
FILLED WITH NON PCB MINERAL OIL [LESS THAN 1 PPM] AT TIME OF MANUFACTURE
  - 7- DECAL READS:  
PRESSURE RELIEVE DEVICE
  - 8- VISIBLE DISCONNECT AND LOAD INTERRUPTER ARE INTERLOCKED SO THAT LOAD INTERRUPTER MUST BE OPEN BEFORE VISIBLE DISCONNECT CAN BE OPERATED.
  - 9- THE LAST TWO OR THREE CHARACTERS OF THE CATALOG NUMBER MUST REPRESENT THE PT RATIO AND MUST BE ADDED AFTER OPTIONAL ITEMS.

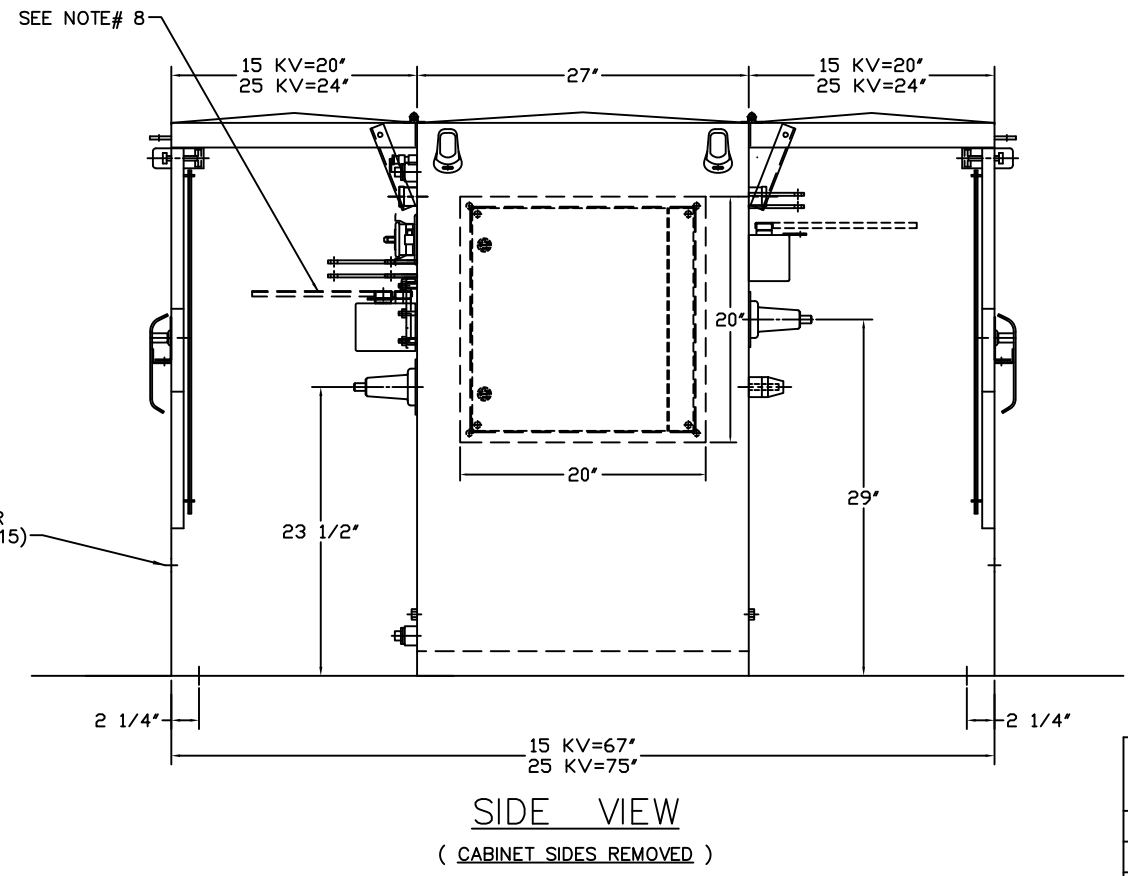

NOMINAL KV	T	S	BIL Ø TO Ø & Ø TO GRD	BIL RATING OF CONTACT
	L	U		
15	CAT.# 3805__54VD3M30		95	95
25	CAT.# 3815__54VD3M30		125	125
APPROX. WT.-LBS.	5075			

OPTIONAL ADDITIONS WITH CATALOG NUMBER SUFFIXES	
CATALOG SUFFIX	DESCRIPTION
A	ALPHA-1 FLUID
D	DRAIN VALVE WITH SAMPLER
K	PROVISION FOR KEY INTERLOCK ON SWITCH HANDLE
LL	2 LIQUID LEVEL GAUGES (ONE IS STANDARD)
M	MANUAL & AUTOMATIC PRESSURE RELIEF DEVICE
N	COPPER GROUND BUS
P	OIL DRAIN PLUG
W	304 STAINLESS STEEL TANK
Y	304 STAINLESS STEEL CABINET

CATALOG LETTER INSERT	BUSHING AMPERE				
	L	R	U	T	S
A	200	200	200	200	200
B	600	600	200	200	200
C	600	600	600	600	600
D	600	200	200	200	200
E	600	600	600	200	200

TRAYER S.O.

TRAYER ENGINEERING CORPORATION  
898 PENNSYLVANIA AVENUE  
SAN FRANCISCO, CALIFORNIA 94107  
(415) 285-7770

SCADA - TEC  
15 & 25 KV LIQUID INSULATED  
PADMOUNTED VACUUM SWITCHGEAR WITH  
VISIBLE DISCONNECT AND VACUUM  
FAULT INTERRUPTERS.

FINISH: DARK GREEN  
MATERIAL: SEE NOTE# 4  
SCALE: 1/8" = 1"  
DR. BY: S. I. DAZA  
CK. BY: BQB  
APPVD: BQB  
DATE: 10-12-04  
UNIT TYPE: PADMOUNT

DRAWING NUMBER: 041004  
REVISION: B  
02-15-05

TOLERANCES ± 1/8"